

260-2210-002 EN06

FST-75 / 150

Operating Instructions

- Translation -

Frequency Converter Control Unit
for sectional doors, roller doors, high-speed doors,
roller-grilles, sliding gates, hinged gates, folding doors
and barriers



Contents

Summary	4
Safety guidelines	5
Installation instructions	6
Important notes	7
Motor frequency.....	7
Voltage boost.....	7
Speeds	7
Stop-Command	7
Cycle counter.....	7
Initial operation	8
Rotation	8
Position displays.....	8
Setting the end positions of mechanical limit switches:	8
Setting the end positions with DES:	9
Rotary switch – How it works	10
Numerical codes – Menu structure	10
Configuration	11
Basic Settings.....	11
Operating mode	11
The safety edge “close” – How it works.....	11
The safety edge “open” – How it works	11
Rated frequency of the motor	11
Maximum voltage boost.....	11
Safety Photocell in close direction - function	11
Positioning.....	12
Set final “open” position (only in connection with DES).....	12
Set final “close” position (only in connection with DES)	12
Set partial opening (only in connection with DES).....	12
Switching position Relay K3 Adjustment (only available with DES)	12
Switching position Relay K4 Adjustment (only available with DES)	12
Setting the functions	13
Safety edge “close” after premature shut down.....	13
Correcting the slowing-down path (only in connection with DES)	13
Closing 1 - automatic locking by time	13
Closing 2 – automatic locking through photo cells	13
Radio control – cable switch	13
Partial opening	13
Running time control for installations with limit switches	13
Setting Smoke and Heat Position (only with DES)	14
Configuration of safety device in opening direction	14

Adjust speeds	15
Free configuration of Relays K3-K8	16
Configure traffic light functions for K5-K8.....	17
Traffic control mode	17
Red traffic light in closed position	17
Extended functions	18
Interlock-system	18
Door open command transmission if interlock-system in ON.....	18
Delayed opening.....	18
Delayed closing.....	18
Setting of service interval.....	18
Detailed description of functions.....	19
Closing edges.....	19
Type 1 : Pressure wave switch (break contact).....	19
Type 2 : Self-monitoring contact edge (closing contact).....	19
Typ 3: Fraba system optical contact edge	19
Safety device in opening direction.....	19
Timer for close 1	19
Closing after release 2 (NVZ).....	20
Start-up delay	20
Dead-man control	20
Radio control – Rope switch.....	20
Partial opening.....	20
Manual/automatic operation	20
Running time control.....	20
Interlock-system	21
Cycle counter.....	21
Relays:.....	21
Level adjustment (only in connection with DES).....	21
Correcting the slowing down path (only in connection with DES).....	21
Smoke and heat function RWA	21
Retrieving information	22
Reset to factory settings.....	23
Softwareupdate.....	23
Loading new software	23
Save software.....	23
Troubleshooting	24
Troubleshooting	25
Technical data.....	27
Appendix	28
Terminal connection plan	28

Summary

Equipment

- Frequency converter with contactor
- Separate brake control
- 6 signal relay
- Amplifier for primary closing edges on closing
- Amplifier for secondary closing edges on opening
- Segment display for basic menu-driven functions programming
- Status display on segment display
- Control keyboard in housing lid
- Connection for drives with mechanical limit switches
- Connection for GFA drives with digital DES limit switch
- Event memory
- Interface for modules which can be additionally obtained

Safety

- Satisfies norms EN 12453 and EN 61508
- Hardware-like emergency shut-down circuit
- Current break in case of CPU failure
- Short circuit resistant control circuit
- Break is deactivated via two independent unsupervised switching elements
- Running time control
- Speed control. Shutdown at 30% excess of speed. A variation with 20% according EN 12453 is optionally available.
- Safety against permanent commands, e.g. defect switches
- Reversing delay

Functions

- Soft start and soft coasting that conserves material
- Step-by-step function for 1-channel radio control
- Automatic closing after time
- Automatic closing after passing through
- Function for permanent operation
- Manual / automatic operation
- Photo-electric cell function with safety function and time reset
- Safety edge function with total or partial reverse
- Safety edge function with/without testing
- Pneumatic or contact edge connection
- Fraba safety system connection without extra amplifier
- Selectable functions for signal relay, from position status to traffic light control
- Automatic recognition of position transmitter
- Programming of end positions (in connection with DES)
- Special configuration possibilities for emergency operation following breakdown of safety facilities
- Cycle counter
- Storage of last errors that arose
- Storage of last configuration amendments made
- locking function

Extras

- Modul for status signaling available
- Softwareupdate via MMC / SD card
- Cable set for motor line and Digital Limiting Switch (DES) available

Safety guidelines

Warning!

Please read these operating instructions prior to operating the unit for the first time! Ensure that the unit has dead voltage prior to conducting any installation and maintenance work! **After the unit has been switched off, there is still a possibility of loaded capacitance carrying dangerous voltage. For this reason, it is vital that you wait between 3 and 5 minutes to allow the capacitance to discharge! Performing work on a hot control board can result in death!** The unauthorised opening and improper intervention on the unit can result in physical injury and damage to property.

To avoid physical injury or significant damage to property, only qualified persons familiar with electrical drive equipment should be allowed to work on the control unit. Qualified persons are deemed to be those who are familiar with the setup, installation, initial operation and running of converters and who have the requisite qualifications for this kind of activity. They must be able to diagnose the tasks they are asked to conduct, recognise potential sources of risk and take adequate safety measures.

The control unit has been built and tested in accordance with DIN EN 12453 "Safety in use of power-operated doors - Requirements" and DIN EN 12978 "Safety in use of power-operated doors – Requirements and testing procedures" and has left the works in fully safe and proper working order. In order to maintain this order and to ensure that it is operated without risk, the user must observe all of the instructions and warnings contained in these operating instructions.

The modification or conversion of the **FST 75/150** control unit is only permissible upon prior consultation with the manufacturer. The operational safety of the supplied **FST 75/150** control unit is only guaranteed if it is used in the manner prescribed. The limit values given in the technical specifications may not be exceeded under any circumstances (see relevant sections in the operating instructions).

When using mechanical limit switches the monitoring of standstill, direction of rotation or speed monitoring is not possible.

Safety regulations

When performing installation work, initial operation, maintenance jobs or testing the control unit, the valid safety and accident prevention regulations must be observed for the specific case in question. Above all, the following regulations must be adhered to. At the same time, no warranty is given for the completeness of the required regulations:

European norms

- DIN EN 12445 Safety in use of power-operated doors – Testing methods
- DIN EN 12453 Safety in use of power-operated doors – Requirements
- DIN EN 12978 Safety in use of power-operated doors – Requirements and test methods

In addition to the above, the normative guidelines of the listed norms must be observed.

- VDE regulations
- DIN EN 418 Safety of machinery
- EMERGENCY OFF Set-up, functional aspects, design guidelines
- DIN EN 60204-1 Electrical equipment with electric accessories
- VDE 0113-1
- DIN EN 60335-1 Safety of household and similar appliances
- VDE 0700-1
- BGV A2 employer's liability insurance association regulations for health and safety
- ZH1/494 Guidelines for power-operated windows, doors and gates.
- Fire prevention regulations
- Accident prevention regulations

Installation instructions

To ensure that the control unit is installed correctly, the following points, among others, must be checked and taken into account:

- The control board must be installed in a suitable housing. The housing must be suitable for use under the local conditions and environment.
- To maintain the IP protective class, it may be necessary to replace the cable entries with screwed cable glands. Where required, additional sealing measures should be taken.
- PVC insulated connecting leads may only be used in interiors!
- All of the poles on the control unit must be fuse protected against short circuiting and overload using a fuse rating of **max. 16 A** per phase. Depending on the design of the control unit, this can occur using a 1- or 3-pole automatic fuse breaker 'F0' (3 x 16 A) which is to be connected in series externally with the control unit in the house installation. In the event of an error, a higher fuse protection may result in the control unit being destroyed!
- When connecting the control unit via a permanent connecting lead using a 16 A CEE plug, please do the following: Install a CEE 16 A socket in the immediate vicinity of the control unit and fuse protect it as described above per phase conductor. Ensure that, once the control unit has been installed, the connecting lead with plug and socket can be accessed at all times!
- If the control unit is permanently connected to the house installation, please do the following: Connect the control unit via a permanently laid installation cable and fuse-protect the control unit as described above per phase conductor. To disconnect the control from the power supply, an additional all-pole cut-off device - such as a main circuit breaker which, at each pole, provides a contact gap which is in compliance with the conditions set forth in Overvoltage Category III for full disconnection - must be attached to the permanently laid installation!
- A risk analysis must be performed. The customer must ensure that the rolling gate, the sliding gate or the lifting element is protected and that no hazardous situations can arise if the final position is overrun.
- A minimum level of protection as well as adequate protective measures must be determined.
- The unit must be secured against the final position being overrun by limit stops, safety limit switches or other safety systems.
- The technical data of the connected power consuming devices such as photo cells or traffic lights must be checked. They must not exceed the permissible connected loads of the control unit.
- Motors must be equipped with a thermal fuse which disconnects the control in thermal overload of the motor.
- The operating frequency of the motor must be in line with the frequency range of the control unit.
- In order to meet the requirements of EMV Directive 2004/108/EG governing electro-magnetic compatibility – in terms of interference emission and resistance to jamming – additional measures will need to be taken when connecting to the FST 75/150. Among other things, this will entail using shielded control and motor wiring. Taking the shortest route, connect both sides of the screening to the relevant PE connection. Run the control and motor wiring in separate cables.
- The parameters for the speed and soft start and soft coasting must be set on site. They must be adjusted to the mechanics of the unit.
- Warning: Longer routes at low frequency may cause the motor to overheat. If necessary, either a PTC or an additional cooler will need to be installed on the motor. Reserve lines have been provided for such an instance (2 conductors).

Important notes

Motor frequency

For the **FST 75/150** to operate at its optimum best and perform all of the required functions, the control unit must be aware of the rated frequency **of the connected motor**. The rated frequency must be set before all other work and settings are performed under menu item 05 (default setting 50 Hz).

Voltage boost

In some applications it is required to adjust the starting current for the motor. For this purpose the FST 75/150 is equipped with a voltage boost feature. It is controlled by a proprietary parameter, which can be changed under menu item 06. The default value of 30 is suitable for most installations. To increase the voltage boost set a value greater than 30. To reduce the voltage boost reduce the value to less than 30.

Speeds

For the FST 75/150 operate at its optimum best and perform all of the required functions, the control unit must be aware of the rated frequency **of the connected motor**. The rated frequency must be set before all other work and settings are performed under menu item 05 (default setting 50 Hz).

Where required or requested, the desired speeds for the slow speed, closing and opening as well as the ramp times can be set at a later juncture by going through menus 40-48.

Through the default settings for the FST 75/150, all drives can usually be run for the installation once the unit is connected to the mains. Where motors with a higher rated frequency are concerned, the maximum speed is reduced during installation for safety reasons (Menus 40-48). Where 50 Hz drives with limit switches are concerned, it is usually only necessary to correctly position the limit switches. In doing so, the pre limit switches initiate the soft coasting. The factory default settings have been set to ensure a harmonious run for 50 Hz motors. Where drives with DES are concerned, only creep speed will be possible at first until the end positions have been programmed. Once the positions have been programmed, the speeds will increase in line with the pre-settings. The ramps adjust automatically. As a consequence, the control unit is now ready for operation.

Sample settings variant for a unit with a 5 m orifice: Fast opening – fast closing up to 2.5 m in height – subsequent closing with reduced speed. **The reduced speed enables the speed to adjust to the installed safety system as a means of adhering to the forces required as per the norm.**

Please test the opening and closing forces after initiation according to EN 12453!

Stop-Command

Important note:

When operating the stop command by internal or external push buttons the stop will occur after a slight delay and will help to conserve the material. An immediate stop followed by an optional automatic reverse only occurs on emergency stop or when the safety edges are activated.

Cycle counter

After setting the FST 75/150 parameters or having completed the initial operation or maintenance work, it is recommended that you register the cycle number which denotes when the last amendment occurred (Menu 93). Safe operation depends, among other things, on the FC being set properly. **Any third-party manipulation may result in damage to property and personal injury.** Using the registered cycle count, it is possible to determine whether the parameters have been amended.

Initial operation

Rotation

Prior to initially switching on the mains power, connect the position transmitters to the terminal strips. After Power-up the door may be operated in dead-man control by using the internal push buttons. The motors turning direction has to accord with the direction of the push buttons. Otherwise please disconnect the controller from supply, wait for 3-5 minutes according to the safety instructions and change two motor connections.

After controlling the turning direction the limits of movement may be adjusted or programmed.

After power-up the controller automatically identifies the kind of limit switching system and is configured in an appropriate way. In case of a false configuration the controller possibly does not allow any movement. In this case a reset of the controller via menu 95 is possible.

Position displays

The door position is indicated in the display by the following symbols:

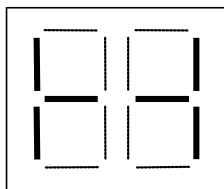

No limit switch

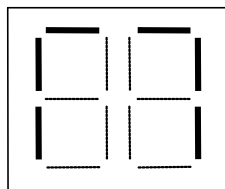

"Open" limit switch

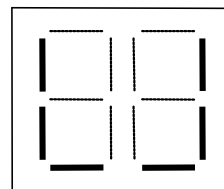

"Close" limit switch

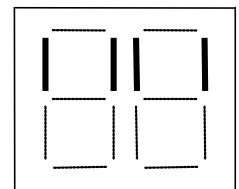

Command to program
"open" limit switch

Setting the end positions of mechanical limit switches:

Warning! The set-up run occurs at 50 Hz in dead-man operation mode! It starts with a ramp.

- a. Set the rated frequency of the motor in Menu 05 (factory default setting: 50 Hz)
- b. Move the door with the internal "open" button into the required final position "open". Stop near to the required end position. Then restart with soft start into the final position "open".
- c. Fix the final "open" position at the correct stop point. The upper segments indicate the achieved end position. Check the shutoff point by opening again and adjust if necessary.
- d. Use the "close" button to move the door to the final "close" position. Stop near to the required end position. Then restart with soft start into the final position "close".
- e. Fix the final position at the switch actuation point. The lower segments indicate the achieved end position.
- f. By the same token, the pre limit switches needed to initiate the ramp motion can be set.
- g. Check the shutoff point by opening again and adjust if necessary.
- h. The unit can now be operated in dead-man control*. For further settings, please go to 'Configuration'.

Setting the end positions with DES:

The DES is a digital limit switch which is installed in drives by the company GFA-Elektromaten GmbH. The DES enables you to program the end positions and also offers further useful options which can be activated via the menus. Once it has detected a DES, the FST 75/150 will show a flashing segment display which indicates the need for programming.

Warning! The set-up run occurs at 50 Hz in dead-man operation mode! It starts with a ramp.

- a. Set the rated frequency of the motor in Menu 05 (factory default setting: 50 Hz).
- b. Move the door with the internal "open" button. Stop near to the required end position. Then restart with soft start into the final position "open". Upper segment displays will flash.
- c. Press the internal STOP button for approx. 3 seconds until the display changes. The "open" position is now saved.
- d. Move the door with the internal "close" button. Stop near to the required end position. Then restart with soft start into the final position "close". Lower segment displays will flash.
- e. Press the STOP button for approx. 3 seconds until the display changes. The "close" position is now saved.

The unit can now be run in dead-man control*. For further settings, please go to 'Configuration'. The end positions can later be adjusted via a menu item.

Displays:

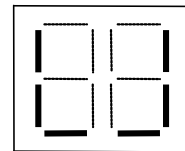
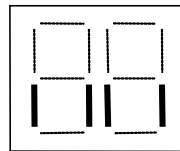
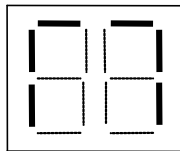
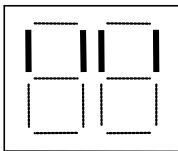

Request for programming of the upper end position

After programming: display of final "open" position

Request for programming of the lower end position

After programming: display of the final "close" position

*Dead-man control: The unit runs for as long as the command station is activated.

Rotary switch – How it works

The rotary switch has two functions. By turning the knob to the left or right, you will be able to retrieve the menu items (segment display), and by pressing the knob, you can confirm your selection.

The following list shows the main and sub-menus which have been assigned a Numerical code or to a display. By setting the Numerical code and then pressing the button, you will switch to the sub-menus and back again.

The means of programming is always the same:

1. **Switching on program mode:** Hold down the rotary switch for 3 secs. The main menu will be displayed (flashing).
2. **Selecting the main menu:** Turn the knob to set the relevant Numerical code and then press to switch to the pertinent sub-menu
3. **Setting functions:** Make the relevant settings by turning to the pertinent Numerical code and press to select. The display will switch to the main menu.
4. **Quit program mode: Turn the rotary switch** until the figure 00 appears in the display and then press the rotary switch.

Numberical codes – Menu structure

Explanations:

Certain menu items are only available in connection with the respective components. When using a DES other menus automatically become activated.

There are 3 types of menu structures:

a) As a rule, following a main menu will be a sub-menu which contains a variety of selection options.

Example: Main menu 21 Function contact edge
 Sub-menus 1 to 3 for selection options

b) A main and sub-menu can also consist of a main menu and a setting parameter.

Example: Main menu 23 Auto time lock
 Sub-menu 0...99 Setting the time (see below)

c) Having selected a main menu, you will need to run a start.

Example: Main menu 11 Correct end position
 Sub-menu -.- Command to run start

Please note:

The positions marked with a "(W)" have been configured as factory default settings.

A 3-digit number will be displayed when changing the display from hundreds digits to tens digits.

Configuration

-- = Position start. Once you have selected such a menu item, press the motion buttons.
(W) = Factory setting

Basic Settings

0.1		Operating mode	save
W	1	Dead-man control in open and close direction	Press the rotary switch
	2	Self-stopping run in the direction of "open" and dead-man control in the direction of "close"	
	3	Self-stopping run in the direction of "open" and "close" Auto switching to dead-man control with internal key or key pad in the event of an error occurring in the safety device	
	4	Self-stopping run in the direction of "open" and "close" Auto switching to dead-man control with internal key or key pad in the event of an error occurring in the safety device	
0.2		The safety edge "close" – How it works	save
W	1	Without reverse	Press rotary switch
	2	With reverse 1 second after "open"	
	3	With reverse up to "open" position	
0.3		The safety edge "open" – How it works	save
W	1	Without reverse	Press rotary switch
	2	With reverse 1 second after "close"	
	3	With reverse up to "close" position	
0.5		Rated frequency of the motor	save
w=50	10..200	Rated frequency of the motor in Hz.	Press rotary switch
0.6		Maximum voltage boost	save
w=30	0..40	Maximum voltage boost on motor startup	Press rotary switch
0.8		Safety Photocell in close direction - function	save
W	1	Stop in close direction without reverse	Press rotary switch
	2	With reverse 1 second in open direction	
	3	With reverse up to open position	
	4	Stop with run in close direction afterwards	

Positioning

1.1	Set final "open" position (only in connection with DES)		save
	-.-	Use the internal keys to move to the required "open" position	Stop key
1.2	Set final "close" position (only in connection with DES)		save
	-.-	Use the internal keys to move to the required "close" position	Stop key
1.3	Fine adjustment of final "open" position (only in connection with DES)*		Save
	-.0	The "open" position can be shifted to "open" or "close" by setting a value	Press rotary switch
	┌.0..9	Shift the "open" position to "open" by x values **	
	└.0..9	Shift the "open" position to "close" by x values ***	
1.4	Fine adjustment of final "close" position (only in connection with DES)*		Save
	-.0	The "close" position can be shifted to "open" or "close" by setting a value	Press rotary switch
	┌.0..9	Shift the "close" position to "open" by x values **	
	└.0..9	Shift the "close" position to "close" by x values ***	
1.5	Fine adjustment of premature shut down (only in connection with DES)*		Save
	-.0	Shut-down point for safety facilities shortly before the final "close" position is reached can be shifted to "open" or "close" by setting a value	Press rotary switch
	┌.0..9	Shift position to "open" by x values **	
	└.0..9	Shift position to "close" by x values ***	
1.6	Set partial opening (only in connection with DES)		Save
	-.-	Use the internal keys to go to the desired partial opening position	Stop key
1.7	Switching position Relay K3 Adjustment (only available with DES)		Save
	-.-	Use the internal keys to go to the desired position	Stop key
1.8	Switching position Relay K4 Adjustment (only available with DES)		Save
	-.-	Use the internal keys to go to the desired position	Stop key
5.1	Switching position Relay K5 Adjustment (only available with DES)		Save
	-.-	Use the internal keys to go to the desired position	Stop key
5.2	Switching position Relay K6 Adjustment (only available with DES)		Save
	-.-	Use the internal keys to go to the desired position	Stop key
5.3	Switching position Relay K7 Adjustment (only available with DES)		Save
	-.-	Use the internal keys to go to the desired position	Stop key
5.4	Switching position Relay K8 Adjustment (only available with DES)		Save
	-.-	Use the internal keys to go to the desired position	Stop key

* possible several time ** turn clockwise *** turn counter-clockwise

Setting the functions

2.1 Safety edge “close” after premature shut down			Save
w	1	Safety edge stops without reversing	Press rotary switch
	2	Safety edge deactivated. Unit moves to final position (in the case of folding doors, for example)	
	3	Level adjustment. Safety edge stops without reversing. Adjustment to change in final position. Conditions: Only with DES, not in connection with pneumatic systems.	
2.2 Correcting the slowing-down path (only in connection with DES)			Save
w	1	The slowing-down path of the unit is not taken into account	Press rotary switch
	2	Shut-down point is corrected around the slowing-down path (dyn. process)	
2.3 Closing 1 - automatic locking by time			Save
w	0	Closing deactivated	Press rotary switch
	1..90	Time setting: 1-90 seconds. Starts after passing the photo cells. In connection with Menu 23.	
2.4 Closing 2 – automatic locking through photo cells			Save
w	0	Closing deactivated	Press rotary switch
	1..90	Time setting: 1-90 seconds. Starts after passing the photo cells. In connection with Menu 23.	
2.5 Radio control – cable switch			Save
w	1	IMP inside = Open – Close IMP outside = Open – Close	Press rotary switch
	2	IMP inside = Open – Close IMP outside = Open – Stop – Close	
	3	IMP inside = Open – Stop – Close IMP outside = Open – Close	
	4	IMP inside = Open – Stop – Close IMP outside = Open – Stop – Close	
2.6 Partial opening			Save
w	1	Connection X5-13/14 defines a switching option for partial opening (Summer/Winter)	Press rotary switch
	2	Connection X5-13/14 defines a command to open in partial open position	
2.9 Running time control for installations with limit switches			Save
w=300	0	Running time control deactivated	Press rotary switch
	5..300	Time setting: 5-300 seconds, starts after command has been given	

Adjust functions

3.5	Setting Smoke and Heat Position (only with DES)		Save
	--	Move drive to desired position with internal push buttons ATTENTION: Opening height must be at least 2,5m	Press rotary switch
3.7	Configuration of safety device in opening direction		Save
w	0	No safety device	Press rotary switch
	1	1 normally closed contact (i.e. photo cell), 1k2 without testing	
	2	2 normally closed contacts (i.e. photo cell), 1k2 without testing	
	3	1 normally open contact (i.e. electrical safety edge) 8k2	
	4	2 normally open contacts (i.e. electrical safety edge) 8k2	
	5	1 System Raytector or OSE	
	6	2 Systems Raytector or OSE	
	7	1 System photo cell with testing	
	8	1 Systems photo cell with testing	

Adjust speeds

Important Information:

The necessary power of the inverter is dependant from wight, acceleration and speed of the site. Modification of frequency through the menu directly changes the speed of the site. Increasing of frequency leads to increasing of speed and therefor increasing of necessary power. Dysfunction of operation possibly leads to an overload of the inverter. In that case the speed has to be reduced to ensure a reliable operation.

4.1	Speed for opening		save
w=50	15..100	Opening with x Hz. Increasing of nominal frequency (Menu 05) changes the adjustable range (max. 200 Hz).	Press rotary switch
4.2	Speed for closing		save
w=50	15..100	Closing with x Hz. Increasing of nominal frequency (Menu 05) changes the adjustable range (max. 200 Hz).	Press rotary switch
4.3	Speed for swifter closing (only in connection with DES)		save
w=0	15..100	Closing with x Hz. To disable function, set value to 0. The changeover is enabled by programming the position (DES s. Menu 44).	Press rotary switch
4.4	Switch point for lowering the closing speed (only in connection with DES)		save
	--	Use the internal keys to go to the required position	Stop key
4.5	Soft start opening		save
w=10	5..50	Duration of acceleration ramp in opening direction / 0.1 seconds	Press rotary switch
4.6	Soft coasting opening		save
w=10	5..50	Duration of deceleration ramp in opening direction / 0.1 seconds	Press rotary switch
4.7	Soft start closing		save
w=10	5..50	Duration of acceleration ramp in closing direction / 0.1 seconds	Press rotary switch
4.8	Soft coasting closing		save
w=10	5..50	Duration of deceleration ramp in closing direction / 0.1 seconds	Press rotary switch
4.9	Creep speed		save
w=10	5..50	Creep speed in Hz	Press rotary switch

Free configuration of Relays K3-K8

The output relays K3-K8 may be freely configured by some functions. For that choose the desired relay in the main menu and choose the function in the sub menu. The sub menu is available for each relay.

To use the relays for traffic lights there are complete function sets to choose from. Please refer to chapter „Configure traffic light functions for K5-K8“.

Relays K3 – K4:

2.7	Relay K3		save
W	0	No function	Press rotary switch
	1	Impulse from intermediate stop position or programmed switch point (see 51)	
	2	Permanent contact from intermediate stop position or programmed switch point (see 51)	
	3	Traffic light function red	
	4	Traffic light function green	
	5	Position indicator “open”	
	6	Position indicator “close”	
	7	Flashing light function	
	8	Beacon	
	9	Fault alarm (safety circuit failure, etc.)	
	10	Power failure alarm	
	11	Control: brake motor	
	12	System runs in open direction	
	13	System runs in close direction	
	14	one of the safety strips is operated between positions (no failure)	
	15	Impulse 1 second with open command (e.g. for light controllers)	
16	Traffic light function red is off at close position		
2.8	Relay K4 (See sub menu 2.7)		save

Relays K5 – K8:

5.5	Relay K5 (See sub menu 2.7)	save
5.6	Relay K6 (See sub menu 2.7)	save
5.7	Relay K7 (See sub menu 2.7)	save
5.8	Relay K8 (See sub menu 2.7)	save

Configure traffic light functions for K5-K8

The FST 75/150 offers some function sets for the control of traffic lights. By choosing one of them, the Relays K5-K8 are automatically configured to the desired function.
For manually configuration please refer to chapter „Free configuration of relays K5-K8”.

6.1		Traffic control mode	Save
w	0	No function	Press rotary switch
	1	One-way traffic without regulation of right of way	
	2	Right of way without preference	
	3	Right of way with preference from inside	
	4	Right of way with preference from outside	
6.2		Extension of green phase time	Save
w	0..90	Setting of Extension time in sec	Press rotary switch
6.3		Time of prewarning	Save
w	0..10	Setting of prewarning time in sec	Press rotary switch
6.4		Doorway evacuation time	Save
w	0..90	Setting of doorway evacuation time in sec	Press rotary switch
6.5		Red traffic light in closed position	Save
w	0	Red traffic light off	Press rotary switch
	1	Red traffic light inside on	
	2	Red traffic light outside on	
	3	Red traffic light inside an outside on	

Extended functions

7.1		Interlock-system	Save
w	0	Interlock-system deactivated	Press rotary switch
	1	Interlock-system activated	
7.2*		Door open command transmission if interlock-system in ON	Save
w	0..10	Delay of opening Door 2 if Door 1 is closed in sec	Press rotary switch

*On command the chosen Door 1 is opened. After closing of Door 1 an open command for Door 2 is given.

7.7**		Delayed opening	Save
W	0	Delay deactivated	Press rotary switch
	3..50	Time-setting 3-50 seconds. Starts after opening command	
7.8**		Delayed closing	Save
W	0	Delay deactivated	Press rotary switch
	3..50	Time-setting 3-50 seconds. Starts after closing command	

** In combination with a relay i.e. for delayed opening, this function allows the operation of a all-round light as opening warning.

In case of double-winged or overlapped doors an appropriate forerun may be activated.

8.5		Setting of service interval	Save
W	0	Function service interval disabled	Press rotary switch
	1..99	Setting of cycles for service of the door. Number of cycles = setting x 1000	
8.6		Service interval reaction	Save
W	0	No reaction	Press rotary switch
	1	Display: CS	
	2	Display: CS and degrade to deadman control	
	3	Display: CS and degrade to deadman control Reset for 500 cycles by pressing Stop-Button for 3 seconds	

Detailed description of functions

Closing edges

The control unit is equipped with three input terminals for safety devices (PSPEs / ESPEs) - one for protecting the main closing edge in closing direction, two for protecting secondary closing edges or drawing-in-points. See circuit diagram for installation.

The closing edge must be connected **prior** to switching on the power supply. The control unit will then evaluate the connected resistance value and thereby define the type of safety facility. Should the safety facility then need to be replaced again by a different type of safety facility, the power supply will need to be switched off and then on again after connecting. If a system should be faulty, a corresponding error alarm will be given and it will only be possible to operate in dead-man control.

The FST 75/150 control unit can evaluate various types of safety devices:

Type 1 : Pressure wave switch (break contact)

Pressure wave switches with a terminal resistance of 1K2 (colour code: brown-red-red-gold). The functioning of this system is tested in the final "close" position. The pre limit switch "close" or the premature shut down on DES is used to initiate the test function.

After premature shut down (shortly before reaching the final "close" position), a period of 2 seconds will count down. Within this time, it is necessary to actuate the system by touching down the contact edge. This actuation tests whether the pressure wave edge is intact. It is then possible to perform a run.

Type 2 : Self-monitoring contact edge (closing contact)

This type of closing edge evaluation is for electric contact edges with a terminal resistance of 8k2 (colour code: grey-red-red-gold). The terminal resistance must be connected at the end of the contact edge or already be integrated.

Typ 3: Fraba system optical contact edge

The principle behind this function is based on that of a one-way photo cell. When the contact edge is actuated, the ray of light is interrupted.

Safety device in opening direction

The safety for opening direction may be realised by photo cells, rope switches or self-monitoring contact edges. 2 provisions may be connected. After activation a release in closing direction is carried out.

The provision has to be configured appropriately. (Refer to menu safety edge in opening direction)

The function of photocells may be tested before each opening.

Only rope switches with forced disconnecter may be used. They have to be prestressed and have to switch a normally closed contact in case of draw or rupture.

Timer for close 1

If this function has been activated, the set time will expire once the final "open" position is reached. After the time has expired, the unit will automatically close. The switching of the photo cells automatically resets the time. A stop command will result in the automatic closing being interrupted.

Closing after release 2 (NVZ)

Each vehicle that passes through is registered by the safety photo cell in the "open" position. So long as the photo cell has been actuated, the safety function will remain intact. Once it has become free or a vehicle has crossed the photo cell, closing will occur after a set time. A stop command leads to the automatic closing being interrupted.

Please note: The door will only close if the photo cell has been actuated. Should no vehicle pass through, the door will remain open. If this is not what is needed, automatic closing 1 can also be activated after a lengthier period of time.

Start-up delay

In order to warn people that activity will be occurring at the door (e.g. by means of a red light), an advance warning time can be set. Only after the advance warning time has elapsed will the door motion be triggered. If an advance warning time has been set in "close", an advance warning will also be made upon automatic closing.

The function may be useful for overlapped turning doors or in case of a previous activation of a bolting device.

In this cases a combination with a relay is necessary (control of traffic light or bolting device).

Dead-man control

The door will only operate for as long as the command is actuated. This function is set for initial operation upon delivery. The function can also be activated as an emergency step via Menu 01 in the event that the safety facility should fail.

Radio control – Rope switch

The FST75 and FST150 offer 2 connections at the terminals „IMP“ for connecting a single switch, a one channel key switch, a radio control or a rope switch. In combination with traffic light with right of way the connections differ between inside and outside.

The command may operate in 2 modes:

- a) On each activation of this input the door is performing an open...stop...close...stop...open...with a movement to the opened or closed position.
- b) On activation the door opens to endposition and may be closed by another activation.

The mode may be changed by the menu.

Partial opening

A selector switch allows you to select between two opening positions. To perform this option, it will be necessary to have an additional limit switch or to program a partial opening position on drives with DES.

Manual/automatic operation

A selection switch allows you to deactivate the automatic timed closing actions. It is possible to operate this manually.

Running time control

An additional protective mechanism for drives with slip clutch. If the current motion exceeds the standard running time, the door will be stopped.

Interlock-system

To build an interlock-system, every door has to be equipped with a controller FST75/150. By using the connectors SLF both controllers are connected. The function is activated by the menu. (refer to menu function). By doing this the doors only move in accordance to the limiting positions.

As an option it is possible to pass over an opening-command.

Example:

A forklift operator opens the first door using a rope switch and closes it using i.e. a photo cell in conjunction with the function "closing after release 2 (NVZ)". The forklift operator moves to door 2. As soon as door 1 has closed, door 2 will open automatically by an opening command from door 1 controller.

Cycle counter

The cycle counter is started upon initial operation and cannot be reset. Using the cycle counters, it is possible to check or set the maintenance intervals for the unit.

Relays:

The FST 75/150 has integrated several functions for the output relays. These functions can be configured independently and individually for each relay. In the standard design, a simple red/green traffic light control with advance warning can be used. However, it is also possible to provide two "OPEN" position indicators, for example. This is especially useful for meeting special requirements.

WARNING! Please observe the maximum load of the relays. Under certain circumstances, it may be necessary to fuse protect the circuit.

Level adjustment (only in connection with DES)

The function cannot be applied to pneumatic systems. The FST 75/150 has the means to adapt the shut-down point of the drive to the changing ground conditions (e.g. installation of the unit prior to the floor being laid). At the same time, the shut-down point "close" undergoes constant change. The unit continues to edge forwards until the safety edge activates. As soon as it activates, the shut-down point is once again brought a little further forward.

Correcting the slowing down path (only in connection with DES)

The FST 75/150 incorporates a function that allows the open and close position of the unit to be kept constant. The path between shutting down the contactors and the unit actually coming to a standstill (slowing-down path) may vary depending on the external influences. This is possible, for example, in the case of thermal loads or when the brake has worn down. The FST 75/150 registers any overrunning of the programmed shut-down position and shuts down the contactors correspondingly sooner on the next run.

Warning! This function may only be activated if the unit regularly undergoes maintenance! This must be performed to ensure that the unit does not take on a dangerous state through prohibited wear and tear or a lack of readjustment, for example (full loss of brake power).

Smoke and heat function RWA

The FST75/150 offers a special Input that reacts to the contact of a building's automativ fire alarm system. In case of fire it may be a benefit if the door opens automatically in case of a fire alarm, so an evacuation or the free entrance of fire brigade is prepared. Doors may move in a position, that allow outlet of smoke and heat.

The smoke and heat command has the highest priority, that is to say, the movement to the programmed position is executed in any way. All safety functions are overridden, except emergency stop!

This function has necessarily to be coordinated with the local fire brigade

The alarm contact has to be applied permanently. If the contact opens, the FST75/150 returns to normal operation.

Retrieving information

9.1	Cycle counter (7-digit)	Selection
0..7	Upon pressing the adjusting knob, 7 digits will be displayed one after another in the <u>right-hand</u> segment. By overlaying the graduation lines in the left-hand segment, it is possible to see how far the digit sequence has run. The first graduation line is for digit 1, the second for digit 2 and so on. The digits written one after another in the <u>right-hand</u> segment represent the number of cycles as a figure. Example: 0003526 for 3526 cycles.	Press adjusting knob
9.2	Display of the last 2 errors	Selection
F..	Upon pressing the adjusting knob, the Numerical codes for the last two errors which have occurred will be displayed alternately.	Press adjusting knob
9.3	Last configuration amendment	Selection
	Upon pressing the adjusting knob, 7 digits will be displayed one after another in the <u>right-hand</u> segment. By overlaying the graduation lines in the left-hand segment, it is possible to see how far the digit sequence has run. The first graduation line is for digit 1, the second for digit 2 and so on. The digits written one after another in the <u>right-hand</u> segment represent the cycle number when the last program amendment was performed.	Press adjusting knob
9.4	Displaying the program version	Selection
	The program version is displayed.	Press adjusting knob

Reset to factory settings

9.5	Resetting to default settings (factory condition)	save
0	On selecting the function, a 0 is displayed. To activate the reset, then actuate the internal Open key. The display will switch to 1.	a. Open key
1	Press the internal stop key for 3 seconds. A reset will be performed.	b. 3 sec. stop button

Softwareupdate

Using a MMC / SD card it is possible to update the controller's software locally or it is possible to store the actual used controller's software.

Loading new software

Note: Previous to updating the software we suggest to save the actual running software (refer to 9.8).

Place the MMC/ SD card with the new controller's software into the SD-card-connector of the FST75/150. Call the menu function 9.7. In the sub menu the digits 0.0 are displayed.

By using the opening- and closing buttons, the stored software versions on the SD-card are scrolled in the display.

The actual software version is displayed in the LED display.

- Using the Stop-button the chosen software version is loaded.
- While loading, a loading signal is displayed (circular turning light), that may pause for a while.
- The end of the loading procedure is indicated by a controller's reset. After the reset the door's position (i.e. Open position) has to be displayed.

9.7	Loading software	Save
0.0	Use open- and close-button to choose software version.	3 Sec. Stop-button

Save software

With this menu the actual running software may be stored on an eternal data medium (MMC/ SD). Place a MMC/ SD-card into the SD-card-connector of the FST75/150. After that please choose the menu and the steps are done.

9.8	Save software	Save
	Call main menu 9.8	Press adjusting knob

Troubleshooting

When the unit is running as normal, the current status of the control unit will be displayed. The display of errors and commands occurs as a series of letters and numbers which are displayed alternately.

- Upon activating a command, flashing lower or upper segments will be displayed on the control unit to indicate the direction of movement currently in operation. Once the position has been reached, the segments will switch from a flashing to a permanent display.
- The activation of a command is indicated by means of an **E** followed by a code.
- An error is indicated by means of an **F** followed by a code.

Display	Description	Remedy
F 1.2	Slip door contact opened	Check whether the slip door is closed or whether a line has been disconnected in the cabling.
F 1.3	Safety circuit DES	Check whether the slack rope contact is closed or whether a line has been disconnected in the cabling.
F 1.4	Emergency Off contact activated	Check whether the emergency Off control unit is activated or whether a line has been disconnected in the connecting lead.
F 1.5	Interlock configuration	One of the controls is not correctly configured. Please check the menu valves.
F 1.7	Slip door switch defective	The slip door switch with monitoring device registers a defect. Check the switch and the line.
F 1.8	Inlet for slip door switch	Power supply for slip door switch has fallen short. Check power supply.
F 2.0	"Close" safety edge not recognised	Check that the safety edge is properly connected or whether the wrong operating mode has been set
F 2.1	Photo cell activated	Check whether the photo cell has been properly aligned or whether a line has been disconnected in the connecting lead.
F 2.2	The "close" safety edge is activated twice in a row during closing	Check whether any obstacles are in the vicinity of the door or whether a line has been disconnected in the connecting lead or the connecting lead has short circuited. Perform the closing operation until the end position "close" is reached
F 2.4	Close safety edge 8k2 activated	Check the activation of the safety edge. The connecting lead may have short circuited.
F 2.5	Close safety edge 8k2 defective	Check the safety edge and connecting lead for possible interruption.
F 2.6	Pneumatic safety edge 1k2 activated	Check the activation of the pneumatic safety edge. The connecting lead may have been interrupted.
F 2.7	Pneumatic safety edge 1k2 defective	Check the pneumatic safety edge and whether the connecting lead may have short circuited.
F 2.8	Pneumatic safety edge 1k2 testing negative	Check function. The activation must occur in the lower final position (confirmation).
F 2.9	Optical close safety edge activated or defective	Check the activation of the closing edge or whether the connecting lead has been interrupted.
F 3.1	Upper emergency limit switch range activated	With the unit idle (dead voltage), back up the unit using the emergency manual handle or reset the upper final position.
F 3.2	Lower emergency limit switch range activated	With the unit idle (dead voltage), back up the unit using the emergency manual handle or reset the lower final position.
F 3.3	Limiting switches	Both limiting switches (open and close) are active.

Troubleshooting

Display	Description	Remedy
F 4.2	Feedback	The motor feeds energy back into the FC which cannot be dissipated. Install brake resistance or reduce speed.
F 4.3	Current overload	Operating frequency is set too high. Motor is incorrectly sized. Door moves sluggishly.
F 4.4	Temperature problem	Clock frequency too high or the ambient temperature too high. Increase additional cooling or break times.
F 4.5	Communication error	Check the cable connection between the WST 18 and the FC board
F 4.6	Brake resistance overloaded	The unit generates too much energy on braking. The brake resistance overloads too often. Reduce speed (Menus 41-48).
F 4.8	Load too high	FC is working in threshold region. Rated frequency of the motor has not been set. The door moves sluggishly or the FC sizing is incorrect. Set the rated frequency, reduce speeds or replace the FC with a more powerful model.
F 5.1	ROM error	Reset the control unit by switching off and on and replace the control unit if necessary.
F 5.2	Register error	Reset the control unit by switching off and on and replace the control unit if necessary.
F 5.3	RAM error	Reset the control unit by switching off and on and replace the control unit if necessary.
F 5.5	DES not active	Check the connection to the DES. Reset the control unit by switching off and on and replace the DES if necessary.
F 5.6	Drive not running	A phase des mains is blocked or has failed. Check the door mechanics. Check the rotary movement of the limit switch shaft. Check the motor connection.
F 5.7	Rotating field incorrect	Exchange the phases on the power supply cables or the motor.
F 5.8	Speed beyond settings	System is accelerating without control. Weight too high.
F 5.9	Running time error	The normal running time for a complete run is exceeded. The drive is blocked. Slip clutch too loose or defective. The limit switch is not yet adjusted, see Troubleshooting.
F 6.2	Safety device in opening activated	Check the connection of safety device in opening direction for disconnection
F 6.3	Safety device in opening defect	Testing of safety device in opening direction negativ or photocell defect.
F 6.4	Open safety circuit 8k2 activated	Check the activation of the safety circuit. The connecting lead may have short circuited.
F 6.5	Open safety circuit 8k2 defective	Check the safety circuit and whether the connecting lead has been interrupted.
F 6.6	Open safety circuit 1k2 activated	Check the safety circuit and whether the connecting lead has been interrupted.
F 6.7	Open safety circuit 1k2 defective	Check the activation of the safety circuit. The connecting lead may have short circuited.
F 6.9	Optical open safety edge activated or defective	Check the activation of the closing edge or whether the connecting lead may have short circuited.
F 7.1	Shut-down error	Drive moves in shut down mode. The brake is defective or moves on emergency manual operation
F 7.2	wrong direction of rotation	Weight too high. Motor can not lift the weight. System moves into contrary direction.
F 8.1	runtime error	runtime in programming mode is too short. It is a longer runtime needed before programming position.

Display	Remedy
E 1.1	An open command is triggered
E 1.2	A stop command is triggered
E 1.3	A close command is triggered

Troubleshooting:

Problem	Cause	Remedy
No start possible and no error is displayed	No limit switches connected	Connect limit switches to terminal strips
	"Open" and "close" limit switches both open	Check limit switches. Check wiring.
	Wrong position transmitter configured	Reset the position transmitter via Menu 9.5
	No position transmitter connected when device switched on	Reset the position transmitter via Menu 9.5
The running speed of the door slows automatically	The brake resistance is loaded too often. Error F 46 is displayed.	The running speed of the door is too high. Reduce the speed or install an FC with a higher performance.
Run time error F 59 upon initial operation	Travel distance set too short. Spacing between limit switches set too short upon delivery, for example	Switch the control unit off and then on again. Correctly position the limit switch.
No reverse function when safety facility activated	The "close" pre limit switch is not connected or no bridging has occurred or no break contact installed (see wiring diagram)	Connect the pre limit switch or bridge

Technical data

	Dim.	FST 75	FST 150
Output Motor			
Rating:	kW	0,75	1,5
Phase current 100% :	A	5	10
	%	100	
Permanent load:	%	220	
Overload factor for 10 s	A	11	22
Overload current:	V	3 x 0...230	
Output voltage:	Hz	200	
Rotary field frequency Fmax.:	Hz	200 Hz	
Feed – Line Side			
Line voltage:	V	1 x 230 ±10%	
Power frequency:	Hz	50/60 Hz ±10%	
Cross-section for connection max.	mm ²	2,5	
Internal fuse protection:	AT	1 x 10	1 x 10
General			
Control voltage:	V	24 DC	
Control current:	mA	10	
Wiring of inputs:		Use only floating contacts	
Supply for external power-consuming devices			
Voltage output:	V	24 DC	
max. power demand:	mA	500	
Relay outputs		Relay outputs	
Type of output:		Potential free, 2 x changeover, 4 x normally open	
max. switching current:	A	ohmic load 1	
Parameter settings			
Door speed:	Hz	10...200	
Creep speed:	Hz	10...50	
Rampe time:	1..3	1=0,5 Sec. / 2=1 Sec. / 3=2 Sec.	
Break initiation		Break initiation	
Type of output:		105 V DC;230 V AC	
max. current:	A	1,5	
Ambient conditions			
Temperature range :		-10...+50°C	
Moisture range:		max. 85%, non-condensing	
Assembly:		Vibration free mounting, e.g. on flat built wall, vertical mounting	
Protective class:		In housing IP 54	
Max. number of cycles:		500.000 cycles	

Component overview

- A1 Frequency inverter FST
- A2 Cooling element
- F1 Fuse 10A
- H1 Segment display
- S1 Menu switch

Connection terminals:

- X1 Power supply
- X2 Motor brake
- X3 Motor cable
- X4 Plug-and-play motor cable (GfA/GTE)
- X5 Limit switches, external command keys
- X6 Plug-and-play DES cable (GfA/GTE)
- X7 Safety edges – OPEN direction
- X8 Signal relays, e.g. for traffic lights
- X9 External command keys
- X10 24VDC power supply for external devices, max. 500 mA
- X11 Safety edges – CLOSE direction
- X12 Internal command keys
- X10 Connector for sluice function (SLF)
- X11 Connector for status/message function (SMF)
- X12 Interface for memory card SD/MMC

Included parts:

- R1 8,2K resistor (color code: grey-red-red-gold)
- R2 8,2K resistor (color code: grey-red-red-gold)
- R3 1,2K resistor (color code: brown-red-red-gold) for PSPE's

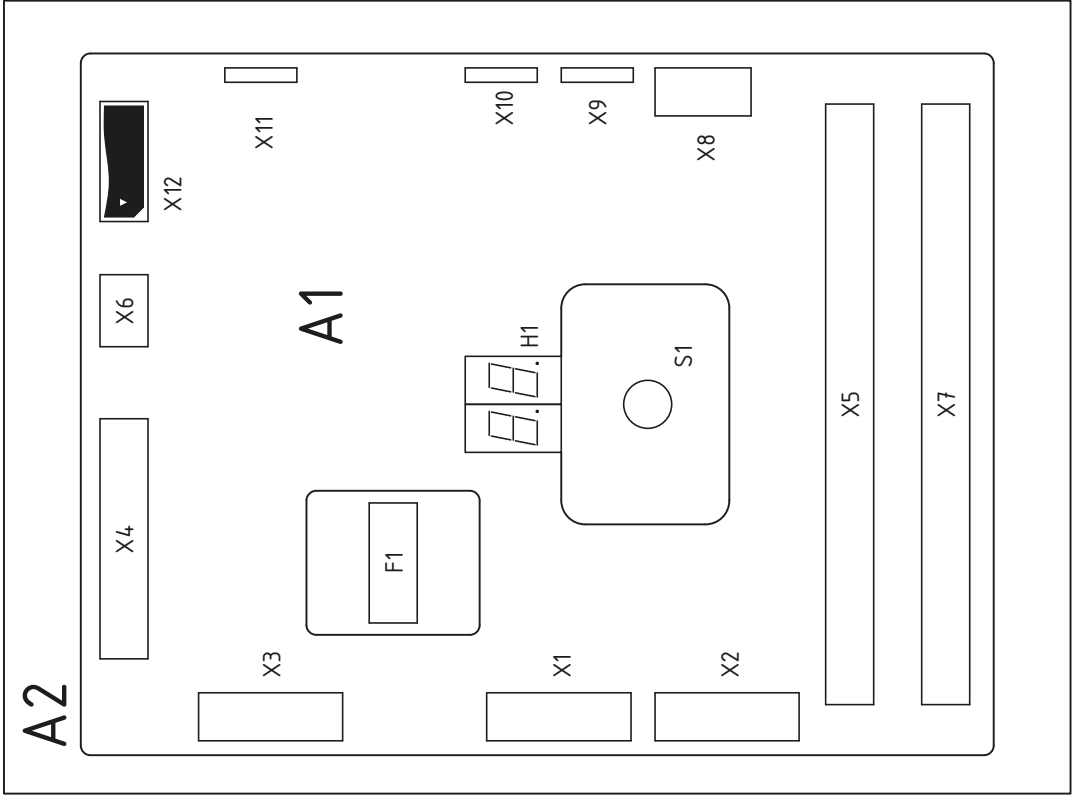

Disconnect unit from power supply before any installation or maintenance work!

Blatt 1		Zeich.-Nr. 260-2210-002 EN06	
von 8		Projekt-Nr.	
Blattinhalt Overview		Benennung Universal Control Unit FST-75/150	
Kunde		 GTE Industrieelektronik GmbH	
Datum 01.02.12	Name Rose		
gezeichnet 29.07.15	gezeichnet Pfeiffer		
gezeichnet			
gezeichnet			

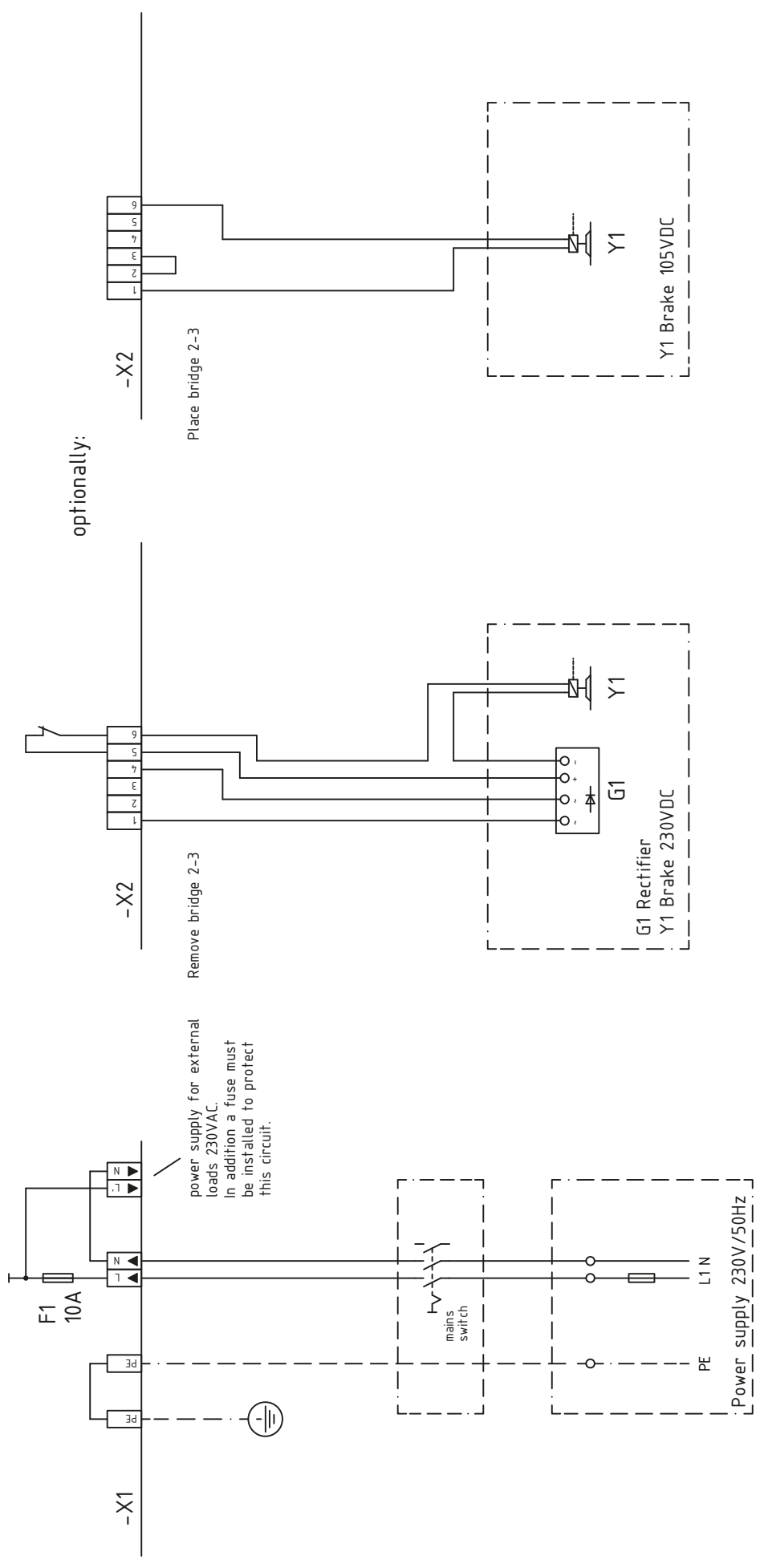

Fuse max. 16A

For motor with brake 230V using rectifier (standard)

For motor with brake 105V

Datum	Name
01.02.12	Rose
29.07.15	Pfeiffer



Kunde

Benennung
**Universal Control Unit
 FST-75/150**

Blattinhalt
**Terminals X1, X2
 Power supply, brake**

Zeich.-Nr.
260-2210-002 EN06

Projekt-Nr.

Blatt
 2

von
 8

optionally:

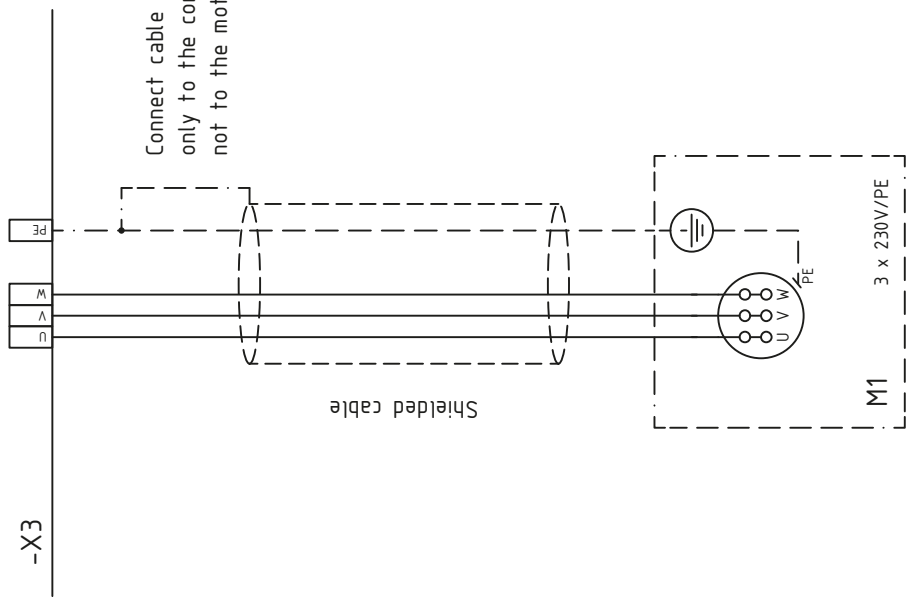

Motor in delta-connection!

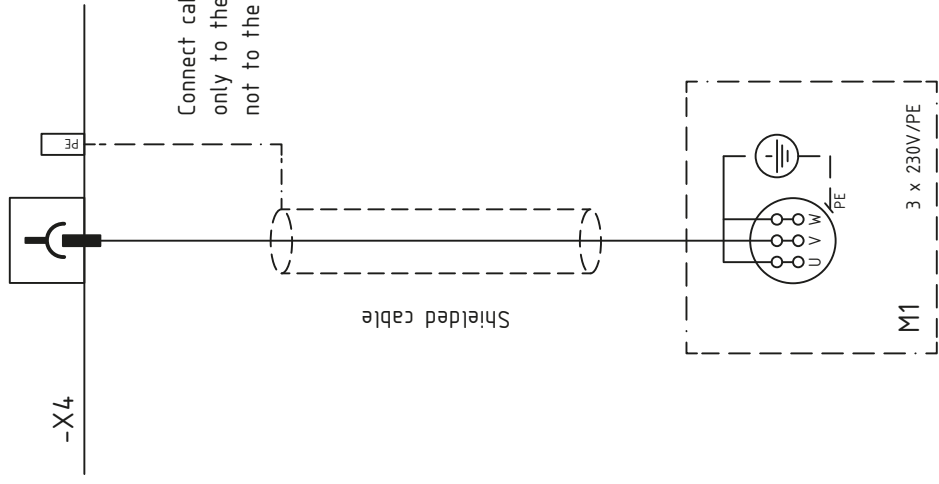

Motor in delta-connection!

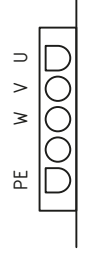

Pin assignment

PIN	Cable-No.
U	1
V	2
W	3
PE	4

grz.	01.02.12	Name	Rose
grb.	29.07.15		Pfeiffer
grs.			
gra.			



Kunde
Universal Control Unit
FST-75/150

Blattinhalt
Terminals X3, X4
Motor

Zeich.-Nr.	260-2210-002 EN06	Blatt	3
Projekt-Nr.		von	8

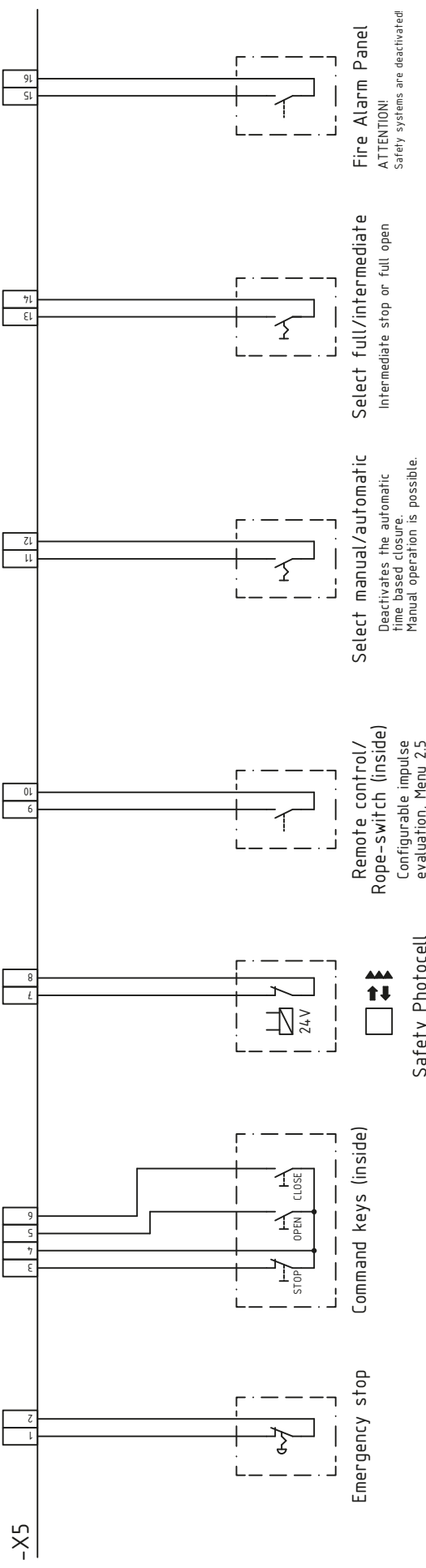

Optional:

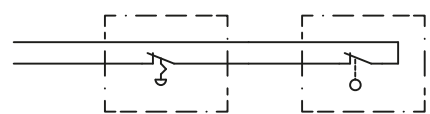

Safety contact
e.g. safety catch

Optional function:
(change in menu)

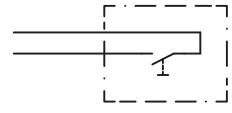

Intermediate OPEN

Remove terminal bridges before wiring!

Emergency stop

Blatt 4		Zeich.-Nr. 260-2210-002 EN06		von 8	
Blattinhalt Terminal X5 Command devices		Benennung Universal Control Unit FST-75/150		Kunde	
Datum 01.02.12 29.07.15		Name Rose Pfeiffer		 GTE Industrieelektronik GmbH	
gez.		gez.		gez.	
gez.		gez.		gez.	
gez.		gez.		gez.	

X6 Connection for drives with limit switches

Application of motors with digital limit switch DES optionally:

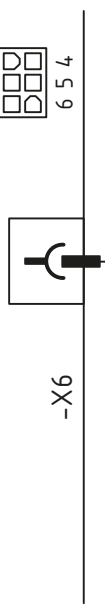
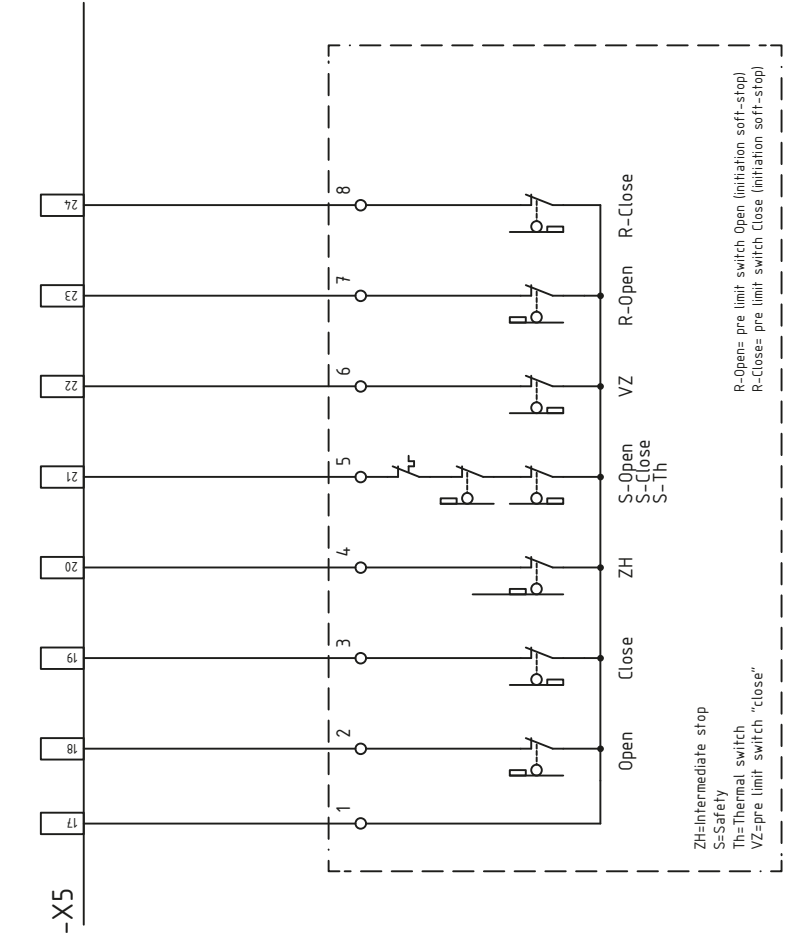

PIN	Cable-No.	Description
1	5	Safety circuit In
2	6	Signal B
3	7	GND
4	8	Signal A
5	9	Safety circuit Out
6	10	8V DC

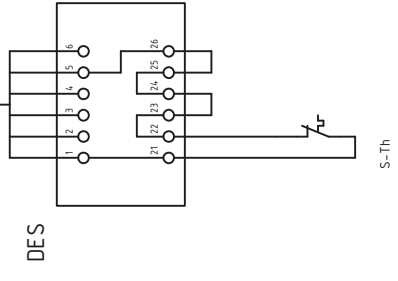

Note! Remove bridge 17-21 if connecting limit switches. Unused NC-contacts are to be shorted.

ge.z.	Datum	Name
ge.s.	01.02.12	Rose
ge.s.	29.07.15	Pfeiffer
ge.s.		
ge.s.		



Kunde

Universal Control Unit
FST-75/150

Blattinhalt
Terminals X5, X6
Limit switch options

Zeich.-Nr.
260-2210-002 EN06

Projekt-Nr.

Blatt
5

von
8

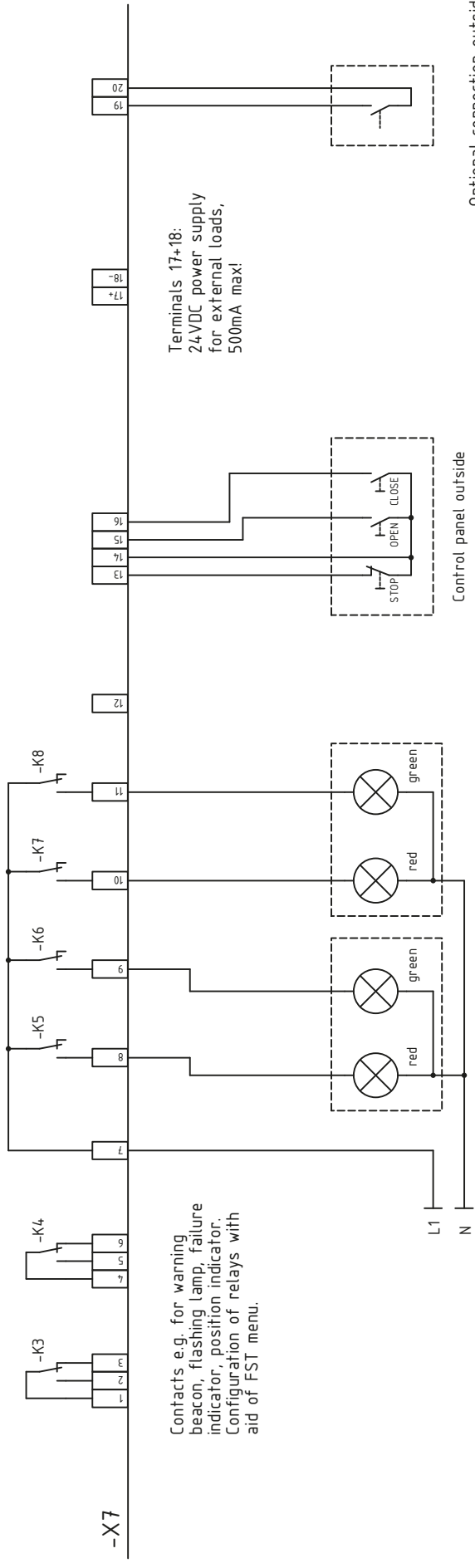

Contacts e.g. for warning beacon, flashing lamp, failure indicator, position indicator. Configuration of relays with aid of FST menu.

Terminals 17+18: 24VDC power supply for external loads, 500mA max!

Control panel outside

Traffic inside

Traffic outside

Optional connection outside:
Radio remote control or cable traction switch.
Contact sequence is selectable:
open-stop-close or open close by menu 2.5

Adjust function of relays with Menu 5.1 - 5.4

ge.z.	01.02.12	Name	Rose
ge.b.	29.07.15		Pfeiffer
ge.s.			
ge.b.			



Kunde
Universal Control Unit
FST - 75/150

Blattinhalt
Terminal X7
Command devices

Zeich.-Nr.	260-2210-002 EN06	Blatt	6
Projekt-Nr.		von	8

Protection OPEN direction
using normally opened contacts
(self testing system)

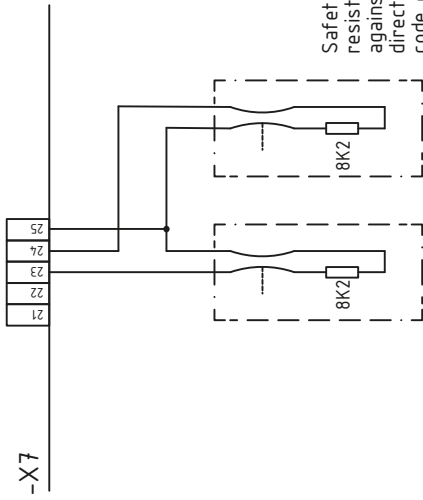

Protection OPEN direction
using system Raytektor / OSE

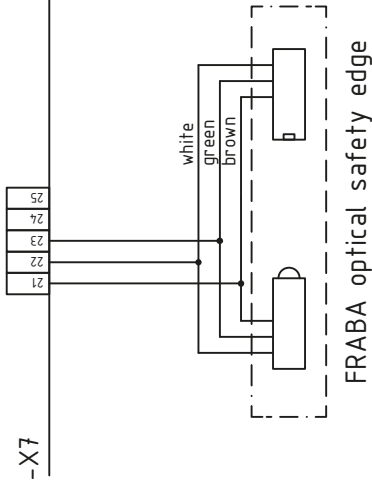

Protection OPEN direction
using safety photocells with testing

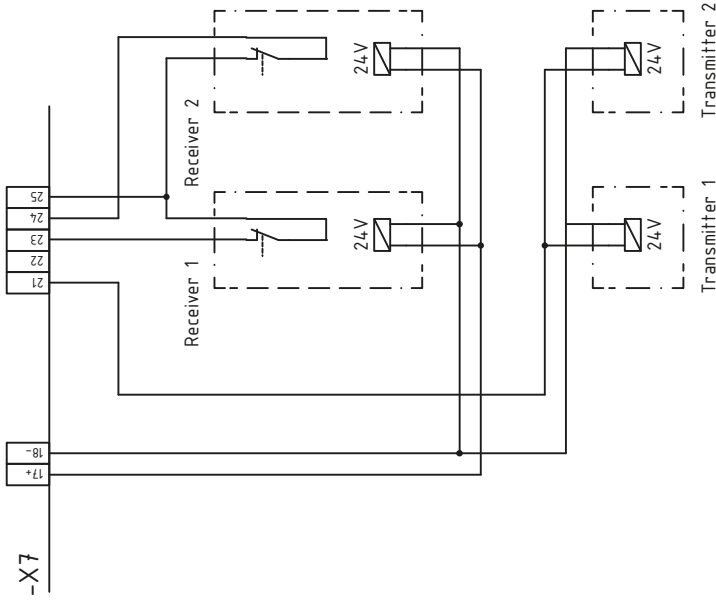

Protection OPEN direction
using normally closed contacts
(photocells, pneumatic system)

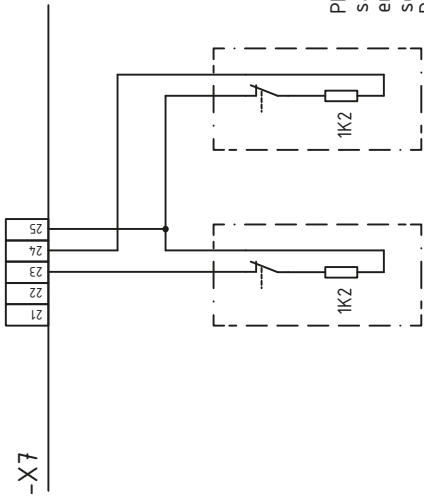

Datum	Name
01.02.12	Rose
29.07.15	Pfeiffer



Kunde

Universal Control Unit
FST-75/150

Blattinhalt
Terminal X7
Safety devices

Zeich.-Nr.
260-2210-002 EN06

Projekt-Nr.

Blatt 7
von 8

Protection CLOSE direction

optionally:

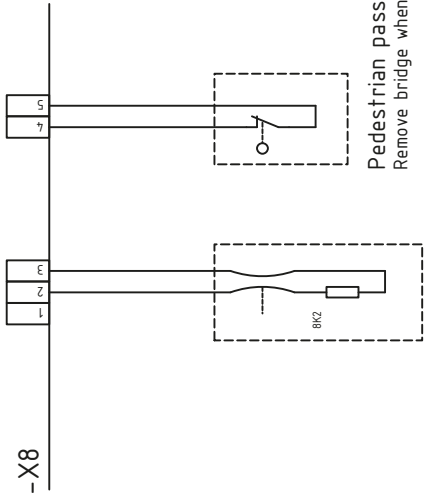

Normally open contacts with 8K2 resistor

Self testing safety edge with 8K2 resistor for protection of the closing direction.

Resistor color code grey-red-red-gold

Protection CLOSE direction

optionally:

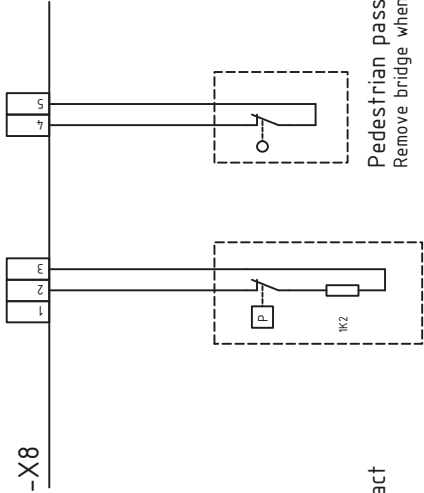

Normally closed contacts with 1K2 resistor

Pneumatic safety edges: Connect 1k2 resistor in series with contact!

Resistor color code brown-red-red-gold

Protection CLOSE direction

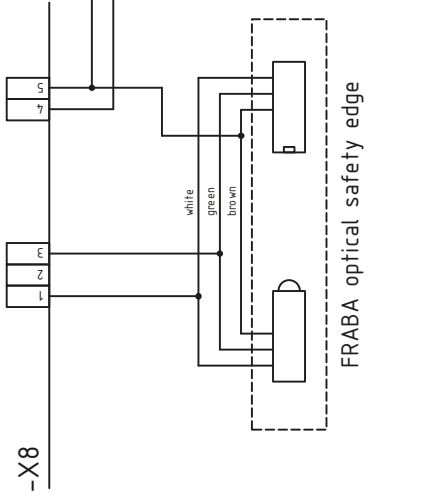

Door contact
Remove bridge
when connecting!

Datum	Name
01.02.12	Rose
29.07.15	Pfeiffer



Kunde

Universal Control Unit
FST-75/150

Blattinhalt
Terminal X8
Safety devices

Zeich.-Nr.
260-2210-002 EN06

Projekt-Nr.

Blatt
8

von
8